

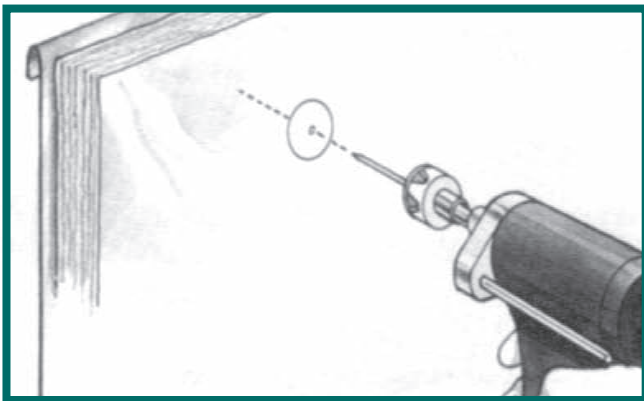

Phone: 1-800-852-8352 • FAX: 937-866-4174
website: www.midwestfasteners.com

GUIDE TO INSULATION FASTENING

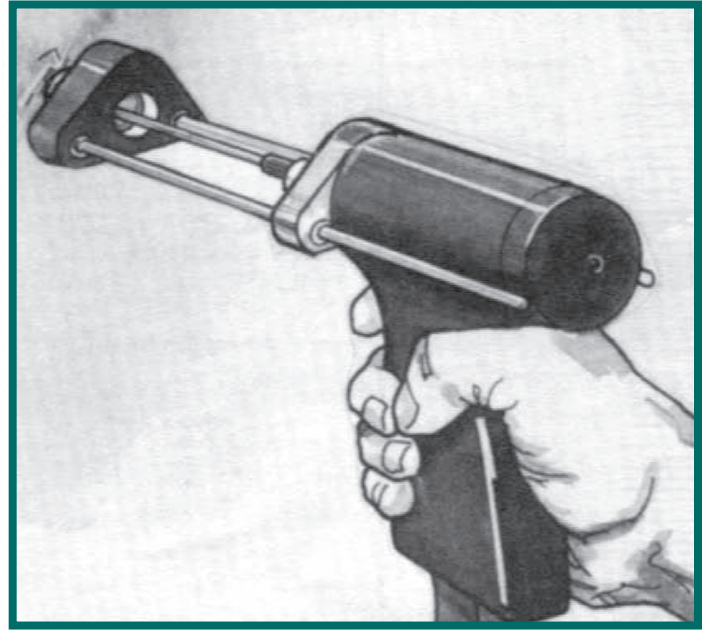
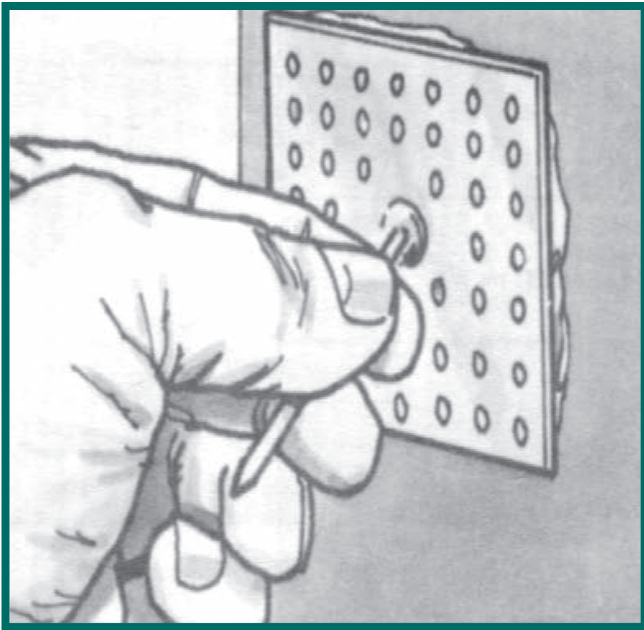

APPLICATION OF WELD PINS



1. WELD PINS IN PLACE.

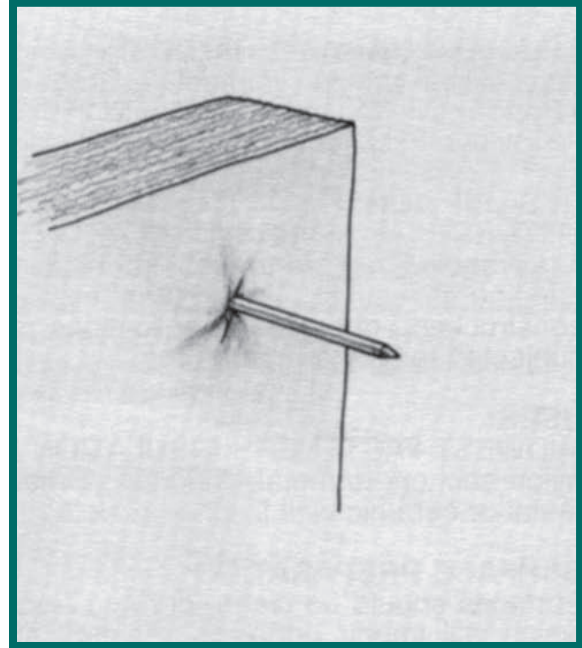

2. INSTALL INSULATION ON PINS.

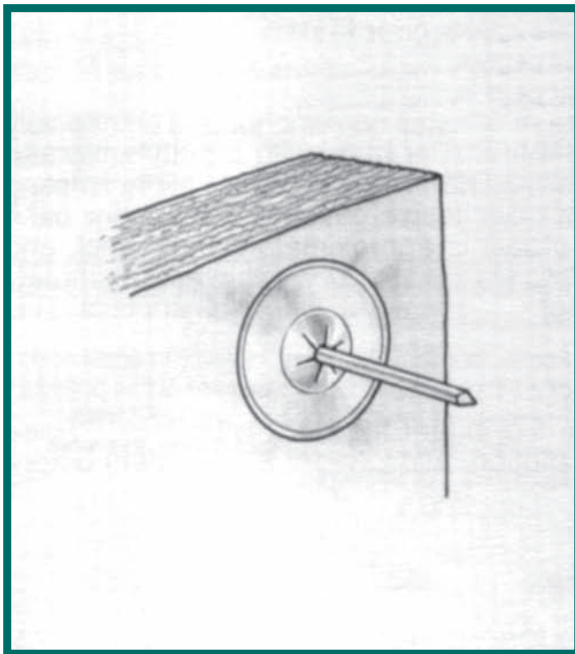

3. PRESS WASHERS ON PINS TO SECURE INSULATION.

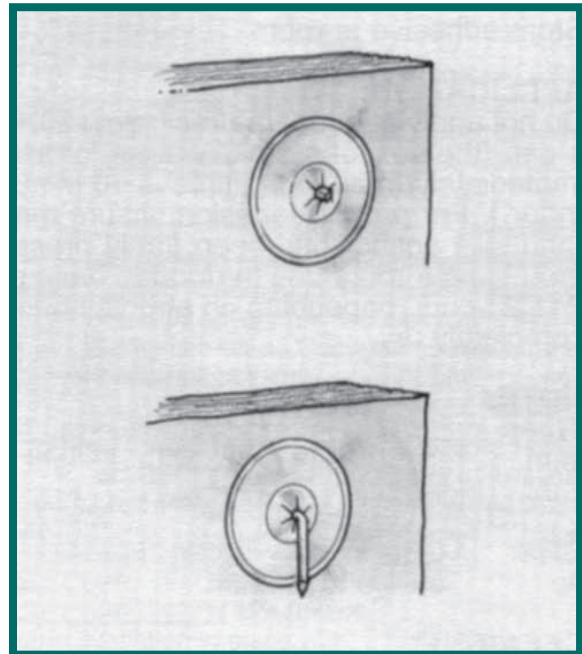

4. EITHER CLIP NAIL OFF AT WASHER... OR BEND NAIL OVER.



Dayton, Ohio
TOLL FREE 1-800-852-8352
www.midwestfasteners.com

HINT: MANY INSULATORS PREFER WELD PINS 1/2" LONGER THAN INSULATION THICKNESS.

WELD PINS ARE AVAILABLE IN MILD STEEL, STAINLESS STEEL AND ALUMINUM.

SPECIAL WELD TIPS ARE AVAILABLE TO WELD THROUGH RUST OR PAINT.

WHAT IS STUD WELDING?

STUD WELDING is a high-speed joining process in which a Stud or similar metal part can be affixed to a metal workpiece.

THE PROCESS: The Stud is placed (with a hand tool called the Stud Gun) in contact with the base metal, an arc is drawn which melts the Stud base and an area of the metal workpiece, the Stud is then forced into the melted area and held in place until the metals re-solidify. This high-quality fusion weld is completed in milliseconds and is accomplished by one of two major methods.

TWO METHODS AVAILABLE are Capacitor Discharge (usually "CD" for short) and Arc Stud Welding.

STUD WELDING SYSTEMS consist of a Power Supply and/or "Controller", a Stud Gun, and cables to tie the system and workpiece together. (See Cable Connections above.)

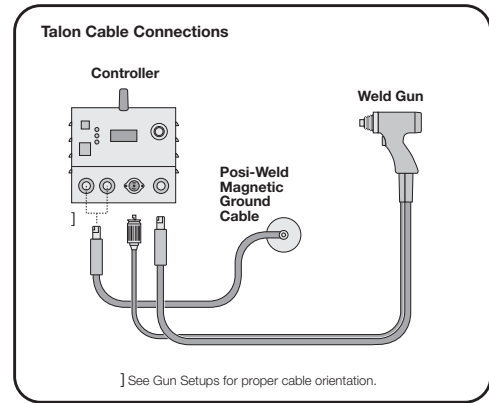

The chart settings shown to the right are "reference" settings to be used as starting points. Actual voltage settings may vary depending upon the conditions or each application and use.

(Midwest Talon settings as shown)

Pin/Stud Type	Pin/Stud Dia	Pin/Stud Mat'l.	Voltage Setting
Cuphead Pin	12 GA	Mild Steel	85-95
Insulation Pin	12 GA	Mild Steel or Stainless	75-85
	10 GA	Mild Steel or Stainless	85-95
Weld Studs (Flanged)	12 GA	Aluminum	110-120
	10 GA	Aluminum	120-130
Weld Studs (Flanged)	#10 or 3/16"	Mild Steel or Stainless	120-130
	1/4"	Mild Steel or Stainless	145-155
Weld Studs (Flanged)	#8	Aluminum	120-130
	#10 or 3/16"	Aluminum	130-140

WELDING ACCESSORIES

CUP HEAD CHUCK

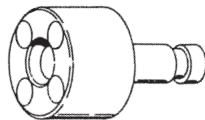

101-0501-XX

"B" COLLETS



101-0102-XX

"B" STOPS



101-1002-XX

"B" COLLET PROTECTOR

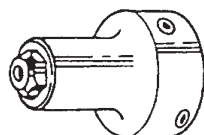

101-0401-XX



Dayton, Ohio
TOLL FREE 1-800-852-8352
www.midwestfasteners.com

WELDING APPLICATIONS

Gun Setup

CUPHEAD PINS

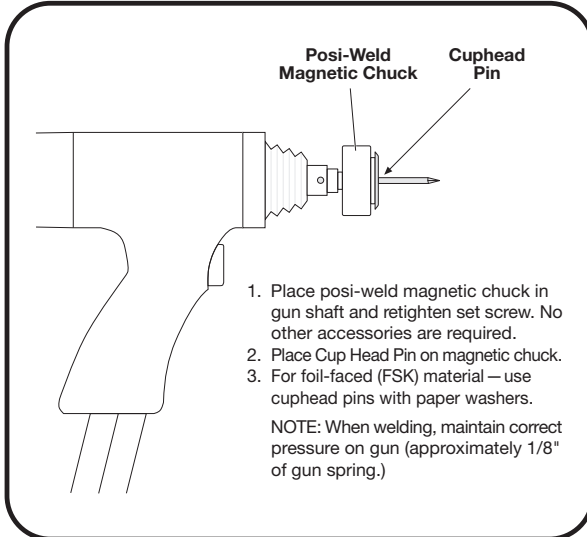
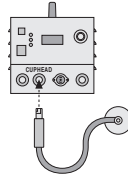

Gun Setup

INSULATION PINS

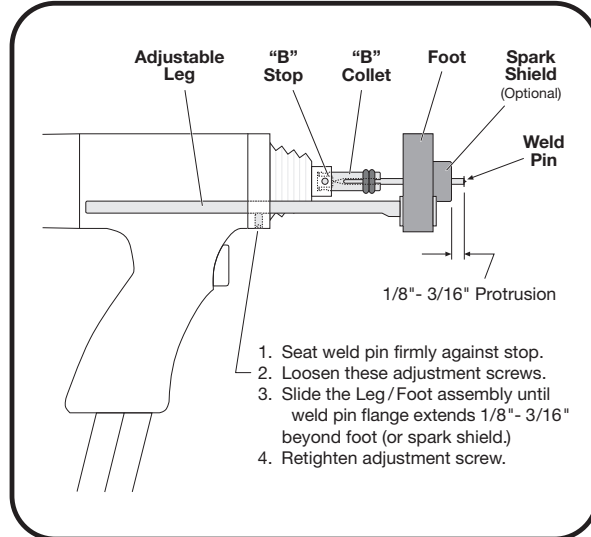
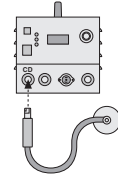

Gun Setup

INSULATION PINS WITH COLLET PROTECTOR

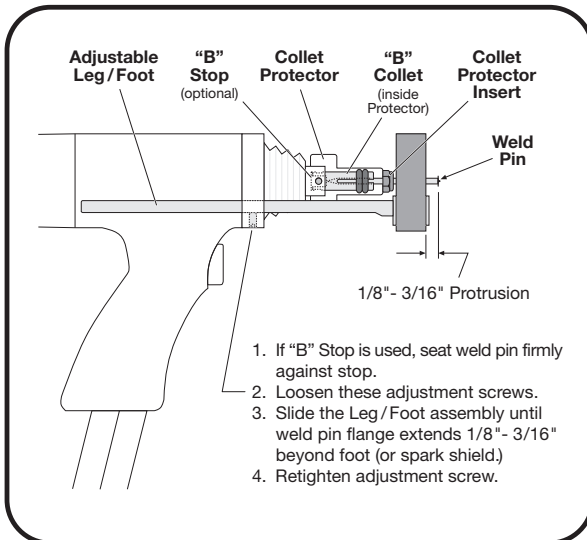
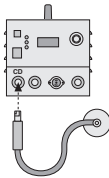

Gun Setup

INSULATION PINS WITH INTERNAL STOP

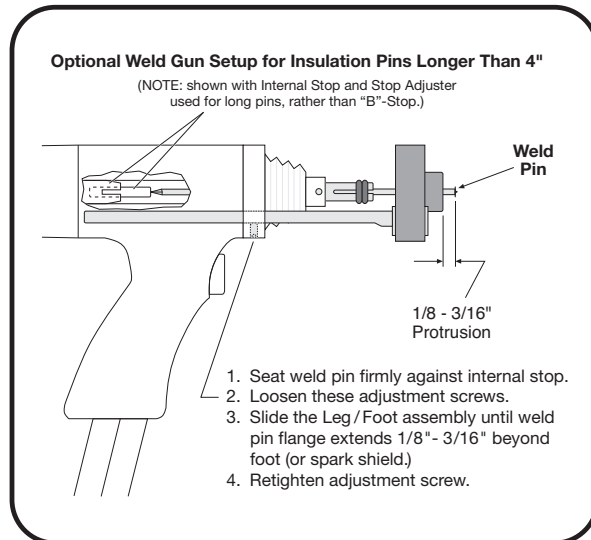
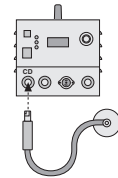

APPLICATION OF CUP HEAD PINS



1. POSITION INSULATION.

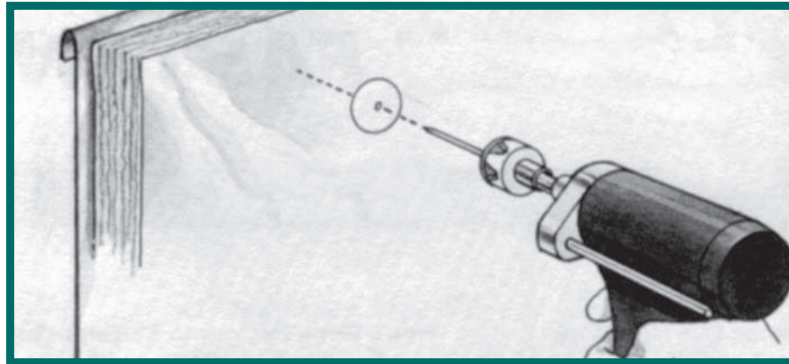

2. PRESS CUP HEAD PIN THROUGH INSULATION.
NOTE – AN INSULATING PAPER WASHER IS REQUIRED
WHEN WELDING THROUGH FOIL-FACED INSULATION.

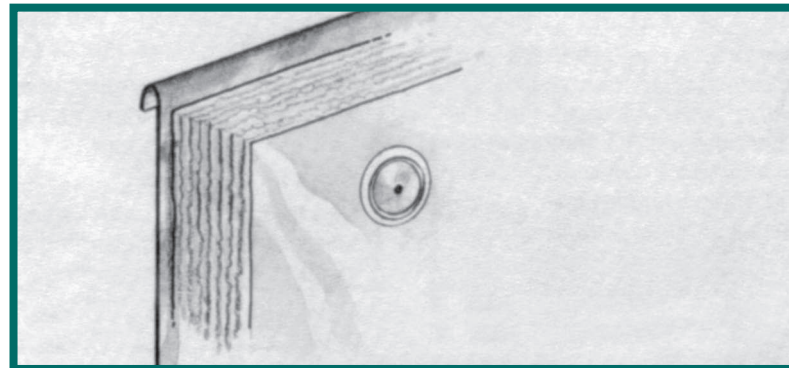

3. WELD IN PLACE TO COMPLETE INSTALLATION.

HINT: MANY INSULATORS PREFER CUP HEAD PINS BE 1/8" LONGER THAN THE INSULATION THICKNESS, DEPENDANT UPON DENSITY OF INSULATING MATERIAL BEING ERECTED.

APPLY ONLY 1/8" TO 1/4" OF GUN PRESSURE TO CUP HEAD AT TIME OF WELD FOR PROPER BURN-OFF AND GOOD WELD QUALITY.

CUPHEADS ARE ALSO AVAILABLE IN STAINLESS MATERIAL.



**MIDWEST
FASTENERS, INC.**

Dayton, Ohio

TOLL FREE 1-800-852-8352

www.midwestfasteners.com

MIDWEST Fasteners

IHA-177 INSULATION HANGER ADHESIVE

Product Data:

MIDWEST Fasteners HANGER ADHESIVE is a high strength, heavy-bodied adhesive, specifically formulated for adhering anchors for hanging insulation.

IHA-177 HANGER ADHESIVE bonds metal and nylon anchors to metal, concrete or masonry surfaces. The product can also be used to install metal or ceramic wall fixtures tile applications.

MIDWEST Fasteners HANGER ADHESIVE is also available for use as a general-purpose construction adhesive in applications requiring a high strength bond, or in applications subjected to high temperatures.

Special Characteristics:

- Excellent thermal shock resistance
- High bond strength
- Water resistant
- Immediate grab
- Mildew resistant
- Non-slip formula

TYPICAL PHYSICAL PROPERTIES AND TECHNICAL INFORMATION:

Base: Thermoplastic Rubber

Type: Solvent

Solids Content: 64%

Color: Light Brown

Weight/gallon: 9.0 lbs./gal.

Shear Strength: Greater than 600 psi (AFG 01)

Water Resistance: Excellent

Consistency: Gun Grade Mastic

Application Temperature: 30°F to 120°F

Extrudability: Excellent (ASTM C 731)

Service Temperature: -30°F to 250°F

Shelf Life: 12 months

Storage Temp: Store at room temperature with cross ventilation.

Clean-up: Mineral Spirits, exercising safe practices
OSHA Class 1B liquid. Store per 29 CFR 1910, 106.

Coverage: 500-1000 anchors per gallon

Flammability: Flammable, Red Label

Flash point: (ASTM D 3828) -9°F

Open time: 15 minutes at 75°F and 50% relative humidity



Dayton, Ohio

TOLL FREE 1-800-852-8352

www.midwestfasteners.com

APPLICATION OF LACING SYSTEMS

A. LACING HOOK SYSTEM

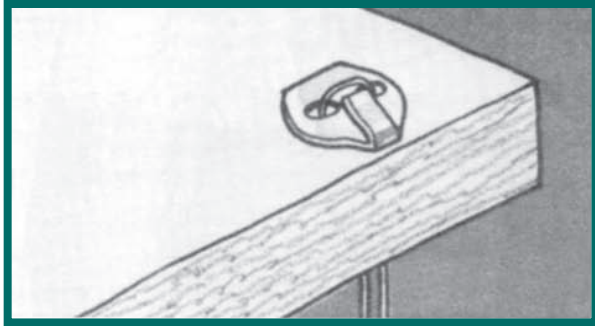

1. INSTALL LACING HOOK WITH TIE WIRE.

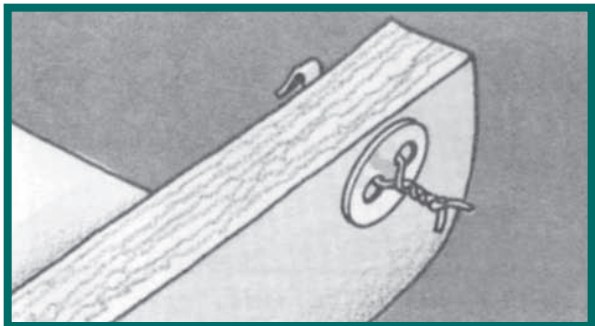

2. SECURE WITH LACING WASHER.

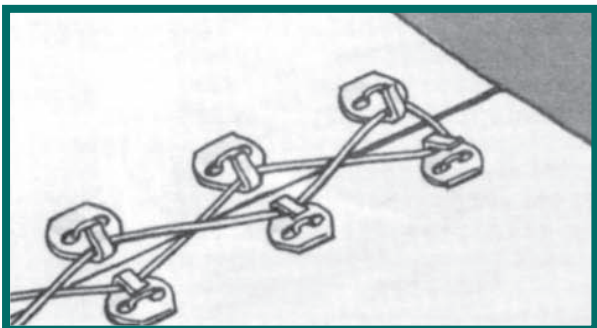

3. SECURE INSULATION BY LACING THROUGH HOOKS.

B. LACING RING SYSTEM

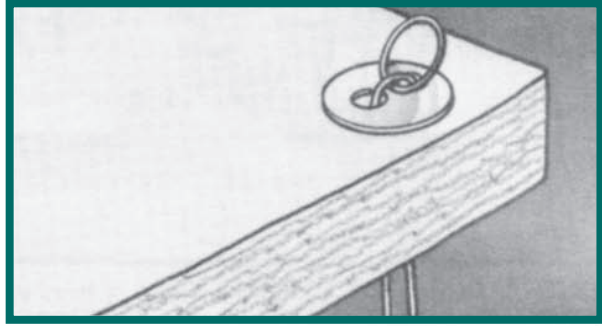

1. INSTALL LACING WASHER & LACING RING WITH TIE WIRE.

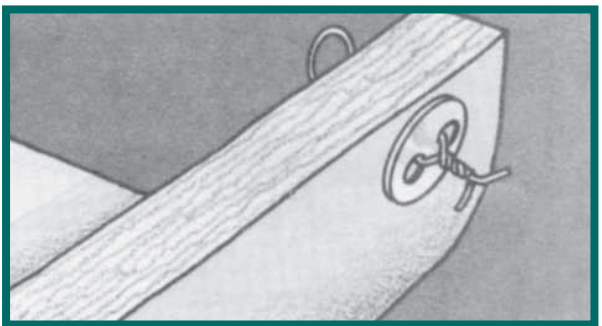

2. SECURE WITH LACING WASHER.

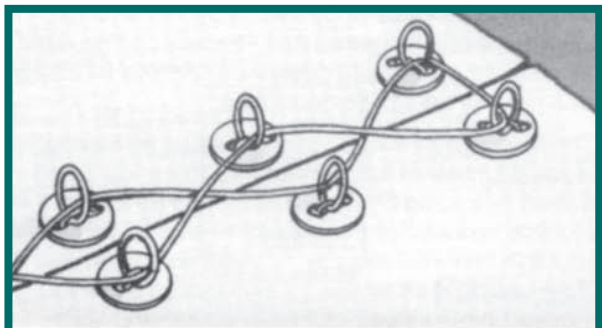

3. SECURE INSULATION BY LACING THROUGH RINGS.

HINT: SOME USERS PREFER NYLON WIRE TIES FOR STEP 3 (WHERE APPLICATIONS PERMIT).

“QUILTING PINS” ARE ALSO AVAILABLE FOR THE OFF-SEAM AREAS OF REMOVABLE PADS & COVERS, AS WELL AS SLIM-STYLE, NARROW WIDTH ANCHORS.



Dayton, Ohio
TOLL FREE 1-800-852-8352
www.midwestfasteners.com

APPLICATION OF LACING ANCHORS

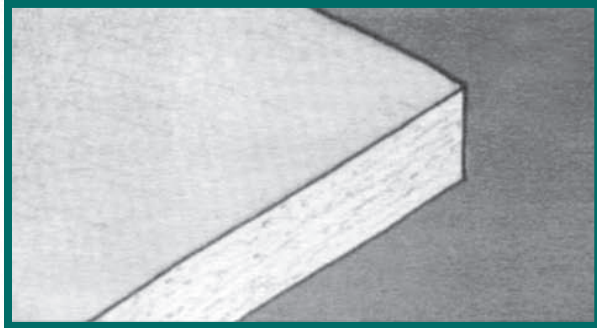

1. PREPARE INSULATION COVER OR PAD TO BE FABRICATED.

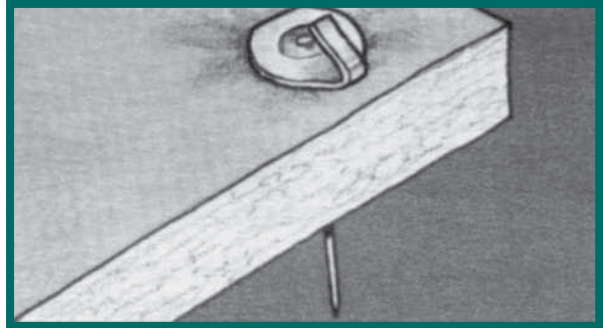

2. PRESS LACING-ANCHOR THROUGH BLANKET.

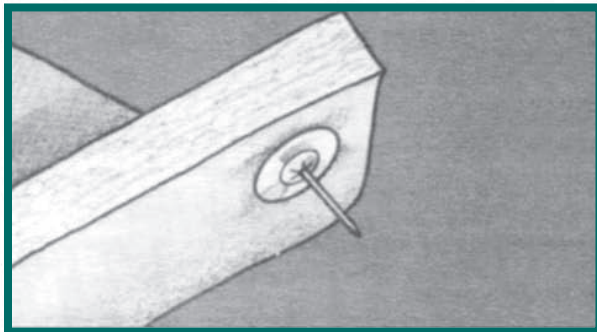

3. SECURE LACING-ANCHOR WITH SELF LOCKING WASHER.

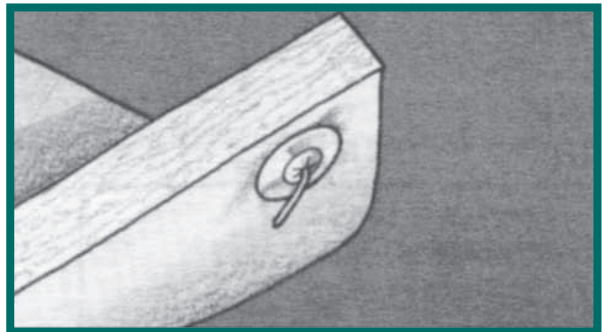

4. BEND OR CLIP-OFF NAIL.

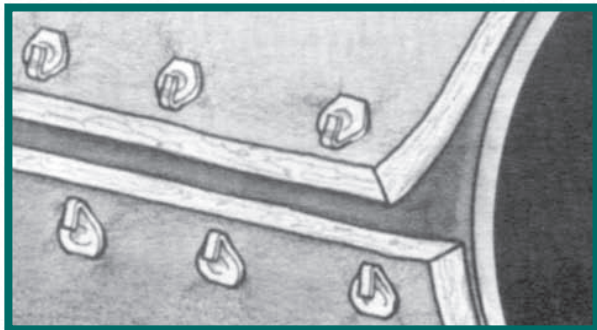

5. INSTALL REMOVABLE FABRICATION.

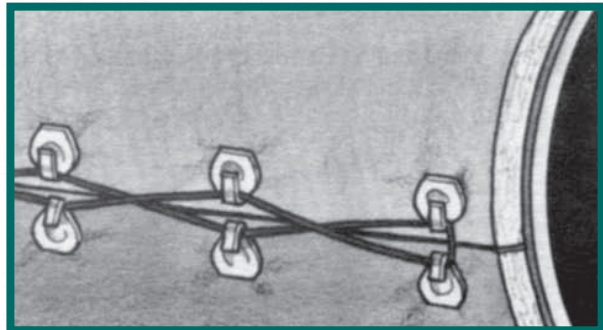

6. SECURE COVER BY LACING THROUGH HOOKS WITH LACING WIRE.



Dayton, Ohio
TOLL FREE 1-800-852-8352
www.midwestfasteners.com

HINT: SOME USERS PREFER NYLON WIRE TIES FOR STEP 6 (WHERE APPLICATIONS PERMIT).

“QUILTING PINS” ARE ALSO AVAILABLE FOR THE OFF-SEAM AREAS OF REMOVABLE PADS & COVERS, AS WELL AS SLIM-STYLE, NARROW WIDTH ANCHORS.

APPLICATION OF INSULATION HANGERS



1. WIPE SURFACE CLEAN.

Anchor must be applied to a clean, dry, non-painted surface.

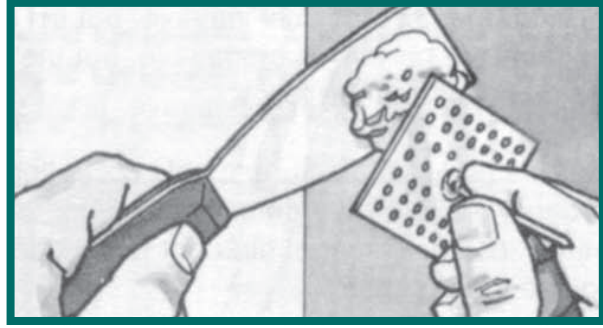

2. APPLY ADHESIVE TO ONE ANCHOR AT A TIME

Spread Anchor Adhesive onto the perforated base with a putty knife.

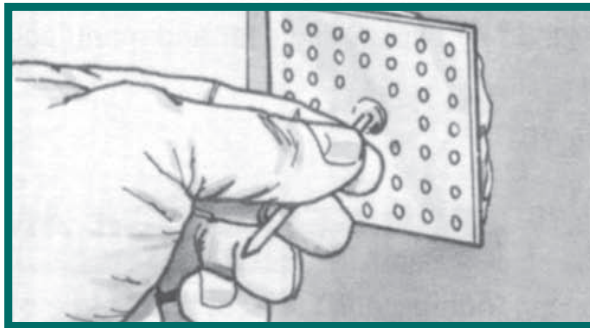

3. IMMEDIATELY STICK ANCHOR IN PLACE.

Press anchor into position with a twisting motion to assure an even spread of adhesive. The adhesive should protrude through the perforations & beyond the edges of the base.

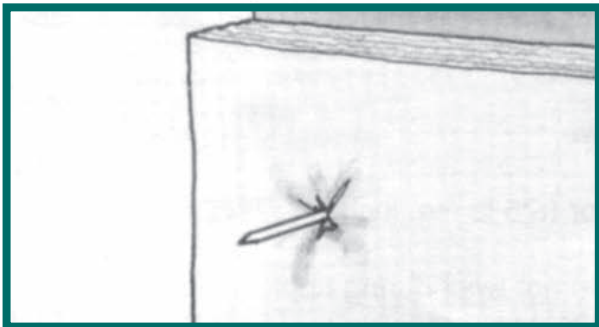

4. INSTALL INSULATION.

NOTE: ALLOW ADHESIVE TO DRY THOROUGHLY before hanging insulation, usually 24-72 hours. Drying times vary with temperature and with adhesive formula in use.

LAYOUT: MIDWEST RECOMMENDS INSTALLATION OF HANGERS ON 12-INCH CENTERS OR 1 (ONE) PER SQ. FOOT.

HINT: EXPECT 700-800 ANCHORS PER GALLON OF ADHESIVE.

UNDER HOT AND/OR HUMID CONDITIONS, ALLOW EXTRA DRYING TIME (CURE) BEFORE INSTALLING INSULATION.

USE OF ANCHOR 1/2" LONGER THAN INSULATION THICKNESS IMPROVES APPLICATION FOR MANY USERS.

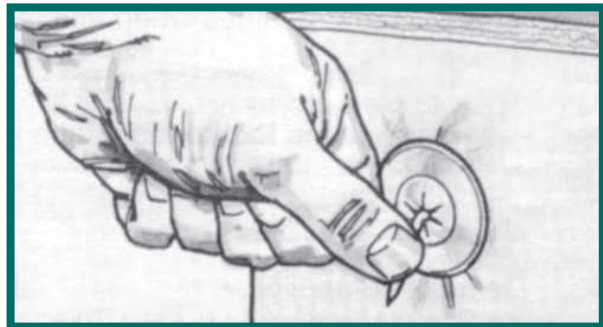

5. SECURE WITH WASHER.

Secure insulation in place with a self locking washer and then bend over or clip off the nail.



Dayton, Ohio
TOLL FREE 1-800-852-8352
www.midwestfasteners.com

IMPORTANT NOTICE TO PURCHASER

All statements, technical information and recommendations contained herein are based on facts we believe to be reliable, but the accuracy or completeness thereof is not guaranteed, and the following is made in lieu of all warranties, express or implied.

Seller's and manufacturer's only obligation shall be to replace such quantity of the product proved to be defective. Neither seller nor manufacturer shall be liable for any injury, loss or damage, direct or consequential, arising out of the use of or the inability to use the product.

Before using, user shall determine the suitability of the product for his intended use and user assumes all risk and liability whatsoever in connection therewith.

No statement or recommendation not contained herein shall have any force or effect unless in an agreement signed by officers of seller and manufacturer.

GUIDELINES FOR SELF-STICK ANCHORS

1. Must be applied to a clean, non-porous surface, that is free of all oil, film, dust, rust, etc.
2. Not generally recommended on painted surfaces, drywall, nor ceilings of metal buildings.
3. Best results are obtained when ambient temperature is above 40 degrees F. at time of application.
4. Temperature range for the foam tape is from -20 degrees to +180 degrees F.
5. Loading should not exceed 3 lbs. per anchor (.75 lb./sq. inch).
6. Base must be applied with firm pressure. Do not twist during application. Do not remove release (backing) paper until ready to use.
7. Insulation may be applied immediately after bond is made.



Dayton, Ohio
TOLL FREE 1-800-852-8352
www.midwestfasteners.com

APPLICATION OF SELF-STICK ANCHORS



1. WIPE SURFACE CLEAN.

Anchor should be applied to a clean, dry non-porous surface.



2. PEEL OFF RELEASE BACKING.

NOTE: Double faced foam tape has a one-year active shelf life.



3. STICK ANCHOR IN PLACE.

Select location before contact with surface. Press firmly.



4. APPLY FIRM PRESSURE.

20 pounds of pressure should be applied all around the base of the anchor.

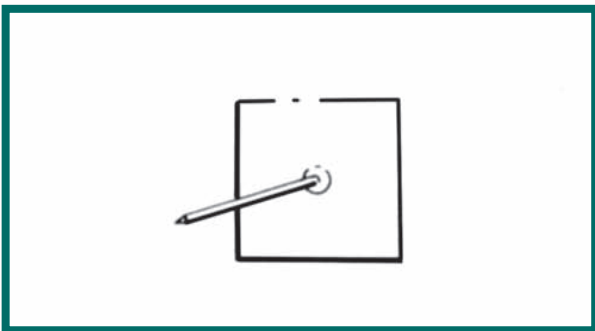

5. ALLOW TO STAND 15-20 MINUTES.

This will permit better adhesion to take place.



6. INSTALL INSULATION AND SECURE WITH WASHER.

Recommended load is 3 lbs. per anchor (.75 lbs./sq. inch maximum).

HINT: USE ANCHORS 1/2" LONGER THAN INSULATION THICKNESS TO IMPROVE INSTALLATION.

DO NOT "TWIST" ANCHOR DURING APPLICATION.

ASSURE APPLICATION TO A CLEAN, DRY, NON-POROUS SURFACE, OBSERVING ALL TEMPERATURE REQUIREMENTS OF THIS TYPE ANCHOR.



Dayton, Ohio
TOLL FREE 1-800-852-8352
www.midwestfasteners.com



450 Richard St. • Dayton, Ohio 45342
e-mail: sales@midwestfasteners.com
website: www.midwestfasteners.com
TOLL FREE: 1-800-852-8352 • FAX: 937-866-4174