

### COMPANY

Johns Manville, a Berkshire Hathaway company, was founded in 1858. Our ownership by Berkshire Hathaway, one of the most admired companies in the world and one of the most financially secure, allows JM to invest for the future. This enables JM to continue delivering the broadest range of insulation products in the industry and offering innovative solutions that meet your needs.

### DESCRIPTION

JM Mineral wool Curtainwall Insulation is made of inorganic fibers derived from basalt, a volcanic rock. Advanced manufacturing technology ensures consistent product quality, with high-fiber density and low shot content for excellent performance. Mineral wool Curtainwall is available in plain or faced with a (FSP) Scrim Reinforced Foil Facing vapor retarder on one face. Mineral wool Curtainwall is inorganic, noncombustible, moisture resistant, non-deteriorating, and will not mildew or support corrosion.

### USE

Mineral wool Curtainwall is designed to provide superior fire resistance and thermal properties in glass, metal, and masonry curtainwall spandrel systems. The board can be placed between or over framing members, and held in place with mechanical fasteners.

### INSTALLATION

Mineral wool Curtainwall is easy to install. It is easily cut with a utility knife for convenient jobsite fabrication. A wide range of thicknesses facilitates optimum material usage.

### PACKAGING

Mineral wool Curtainwall is packaged in poly shrink wrap.

### DESIGN CONSIDERATIONS

Mineral wool Curtainwall may also be used in fire-rated wall assemblies as required by the building code. A fire suppression system may also be needed in conjunction with good construction practices to provide adequate fire protection for the building. The need for and the placement of a vapor retarder in commercial construction depends on many factors. The architect or specifier should evaluate the requirements for each project. Two-hour and three-hour fire-rated assemblies are listed in the UL Fire Resistance Directory.

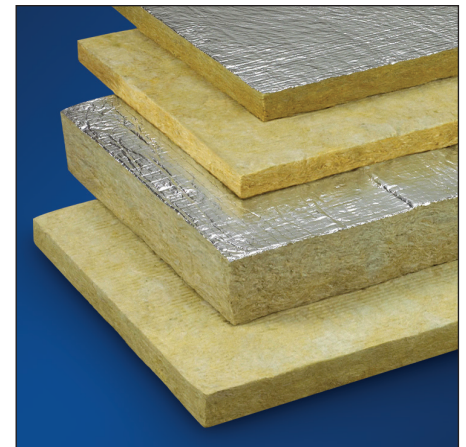

### PERFORMANCE ADVANTAGES

#### Excellent Acoustical Performance:

Lightweight, flexible insulation batts are excellent sound absorbers, efficiently reducing sound transmission.

**Fire Safety:** Mineral wool Curtainwall has a melting point in excess of 2000°F (1093°C). See Applicable Standards for details.

**Noncombustible:** See Applicable Standards for details.

**Durable & Inorganic:** JM mineral wool Curtainwall does not support growth of fungi, nor does it sustain vermin.

### ENERGY AND ENVIRONMENT



### Typical Perimeter Fire Containment Joint

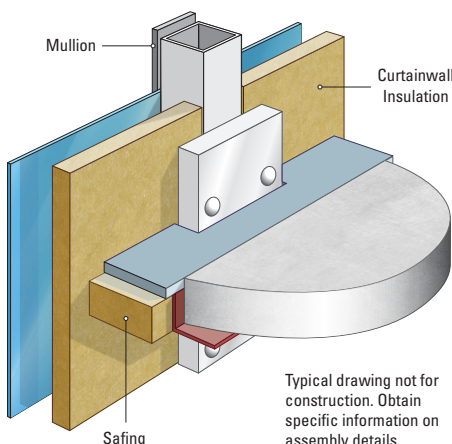

Typical drawing not for construction. Obtain specific information on assembly details.

*\*GREENGUARD certification is not intended for residential environments. Instead, the certification is intended only for buildings meeting ASHRAE 62.1-2007 commercial building ventilation rates. This certification is proof that the product meets the GREENGUARD Environmental Institute's indoor air quality standards and product emission standards for VOCs.*

### LIMITATIONS OF USE

Check applicable building codes.

### APPLICABLE STANDARDS & BUILDING APPLICATION\*

MINERAL WOOL CURTAINWALL
ASTM C423 Noise Reduction Coefficient (2"[51mm], Type "A" Mounting), 1.05
ASTM C612 Material Specification, Types 1-4
ASTM C665 Corrosivity to Steel, Passes
ASTM C1104 Water Vapor Sorption, <1% By Weight; <.02% by Volume at 120°F (49°C), 95% RH
ASTM C1338 Fungi Resistant, Passes
ASTM E84 Flame Spread/Smoke Developed, Unfaced 0/0 or less; Faced 25/5 or less
ASTM E96 FSP Facing Permeability, 0.02 Perms, Maximum
ASTM E136 Noncombustible, Passes
UL 723, CAN/ULC-S102-M, Unfaced 0/0 or less; Faced 25/5 or less
CAN4-S114-M, Passes
City of New York, MEA-346-90
ICC (International Building Code), All Building Classification Types

**\*DISCLAIMER:** JM products are designed, manufactured and tested to strict quality standards in our own facilities. This, along with third-party auditing, is your assurance that this product delivers consistent high quality.

### STANDARD SIZES

PRODUCT	DENSITY ASTM C612		R-VALUE/inch (hr <sup>2</sup> ft <sup>2</sup> °F/Btu)	RSI-VALUE/25mm (°K·m <sup>2</sup> /W)	WIDTH in (mm)	LENGTH in (mm)	THICKNESS*	
	NOMINAL	ACTUAL					UNFACED	FACED
	pcf (kg/m <sup>3</sup> )	pcf (kg/m <sup>3</sup> )					in (mm)	in (mm)
<b>CW4</b>	4.0 (64)	3.0 (48)	4.0	0.70	24 (610)	48 (1219)	1.5–4 (38–102)	>3 (>76)
<b>CW8</b>	8.0 (128)	6.0 (96)	4.2	0.74	24 (610)	48 (1219)	1.5–4 (38–102)	>1.5 (>38)

\*Thickness range available in ½" (13mm) increments. Custom lengths, widths and thicknesses are also available. R-value is determined in accordance with C518.

### ACOUSTICAL PERFORMANCE

#### ASTM C423 Test Method

PRODUCT	THICKNESS in (mm)	SOUND ABSORPTION COEFFICIENTS						
		1/3 Octave Band Center Frequencies, Hz						
		125	250	500	1000	2000	4000	NRC
<b>CW4</b>	1½ (40)	0.13	0.48	1.02	1.08	1.02	1.01	0.90
	2 (50)	0.20	0.61	1.07	1.06	1.04	1.07	0.95
	4 (100)	0.88	1.14	1.17	1.08	1.06	1.10	1.10
	6 (150)	1.32	1.14	1.11	1.09	1.06	1.07	1.10
<b>CW8</b>	1½ (40)	0.13	0.64	1.08	1.04	1.04	1.07	0.95
	2 (50)	0.32	0.90	1.11	1.01	1.01	1.05	1.00
	4 (100)	1.11	0.91	1.03	1.06	1.06	1.07	1.00