



**Industrial Insulation Group, LLC**

A Calsilite/Johns Manville Joint Venture

# MINERAL WOOL INSULATIONS COMMERCIAL

## MinWool® Safing SOUND AND FIRE CONTROL INSULATION

### DESCRIPTION

IIG MinWool Safing Insulation is made of inorganic fibers derived from basalt, a volcanic rock, with a thermosetting resin binder. Advanced manufacturing technology ensures consistent product quality, with high fiber density and low shot content, for excellent performance. Safing insulation is available plain or faced with a (FSP) Scrim Reinforced Foil Facing vapor retarder on one face. MinWool Safing is inorganic, non combustible, moisture resistant, non deteriorating and will not mildew or support corrosion.

MinWool Safing is **GREENGUARD Indoor Air Quality Certified®** for low chemical emissions.

### ADVANTAGES

**Fire Safety.** MinWool Safing Insulation has a melting point in excess of 2000°F (1093°C) and the unfaced insulation is classified as noncombustible by the model building codes. When installed in approved systems, the insulation provides up to a three hour fire resistance rating when tested in accordance with ASTM E119 (UL 263, NFPA 251).

**Low Smoke & Flame Spread.** When tested in accordance with ASTM E84, UL 723, CAN/ULC-S102-M, the unfaced insulation has a flame spread rating of 5 and a smoke developed rating of 0. The faced insulation has a flame spread rating of 25 and a smoke developed rating of 5.

**Non Combustible.** Unfaced MinWool Safing is rated as noncombustible in accordance with ASTM E136 and CAN/ULC CAN4-S114-M as defined by NFPA standard 220.

**Quick Installation.** MinWool Safing Insulation is easy to install. It is easily cut with a utility knife for convenient job site fabrication. It is easy to compress to fit tightly between the curtainwall insulation and the floor slab. MinWool Safing Insulation is packaged in polyshrink wrap.

**Mold Resistant.** IIG MinWool does not support growth of fungi.

**Does not sustain vermin.**

### APPLICATIONS

MinWool Safing insulation is designed to be installed between the spandrel panel and floor slab in commercial curtainwall systems to provide a fire-rated seal. It also prevents the passage of flame and smoke in openings that penetrate fire rated assemblies.



## MinWool® Safing

### DESIGN RECOMMENDATIONS

MinWool Safing should be specified to meet building code requirements as a firestop or as part of a fire-rated joint, perimeter, wall, floor, ceiling, or other assembly as required. Two hour and Three hour fire rated assemblies are listed in the UL Fire Resistance Directory.

### AVAILABLE TYPES

MinWool Safing Insulation is available in a standard size of 4" (102 mm) thick by 24" X 48" (610 mm x 1219 mm)\*. MinWool Safing Insulation can also be furnished in other thicknesses and sizes on special order. Minimum order quantities will apply.

*\*MinWool Safing is available on a made-to-order basis with FSP facing on one side only.*

### INSTALLATION

MinWool Safing should be installed according to the architect or project specifications and the instructions in the assembly listing. MinWool Safing Insulation is easily cut with a knife for quick installation and easy sizing. Install the insulation as specified in the listing or as required by the project drawings and specifications. Leave no voids. Compress the insulation as needed into all penetrations in fire-rated floor slabs and partitions. Completely fill voids around various assembly penetrations. Butt ends and edges closely together and fill all voids with additional insulation.

### ADDITIONAL INFORMATION, MSDS AND LEED® CERTIFICATION

Please visit our website at [www.iig-llc.com](http://www.iig-llc.com).

Typical Perimeter Fire Containment Joint

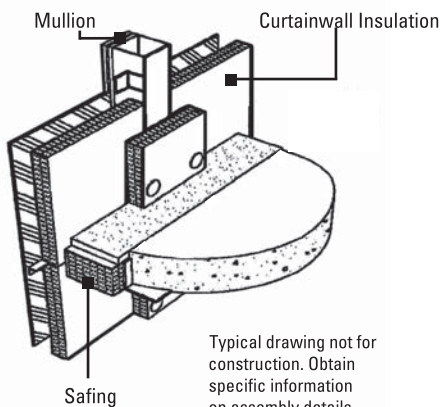

Typical drawing not for construction. Obtain specific information on assembly details.

[www.iig-llc.com](http://www.iig-llc.com)

Your insulation partner in a safer work place and world.



# MinWool® Safing

## SOUND AND FIRE CONTROL INSULATION

SPECIFICATION COMPLIANCE	
ASTM C612 Material Specification (HH-I-558B)	Type 1-4
ASTM C665 Corrosivity to Steel	Passes
ASTM C814 Through-Penetration Firestopping	Passes
ASTM C1104 Water Vapor Sorption	<1% By Weight <.02% by Volume at 120°F (49°C), 95% RH
ASTM C1338 Fungi Resistant	Passes
ASTM E84 Flame Spread/Smoke Developed	Unfaced 5/0 or less; Faced 25/5 or less
ASTM E96 FSP Facing Permeability Method A	0.02 Perms, Maximum
ASTM E136 Noncombustible	Passes
UL 723, CAN/ULC-S102-M	Unfaced 5/0 or less; Faced 25/5 or less
UL1479 Through-Penetration Firestopping	Passes
CAN4-S114-M	Passes
City of New York	MEA-346-90
ICBO (Uniform Building Code)	All Building Classification Types
BOCA (National Building Code)	All Building Classification Types
SBCCI (Standard Building Code)	All Building Classification Types
ICC (International Building Code)	All Building Classification Types
Density	4.0 pcf (64 kg/m <sup>3</sup> )
R-Value @ 75°F	4.0 per inch (0.67 per 25 mm) of thickness

Thickness range available in 1/2" (13mm) increments. Custom lengths, widths and thicknesses are also available. R-Value determined in accordance with ASTM C518. The higher the R-Value, the greater the insulating power.

### PRODUCT CERTIFICATION

When ordering material to comply with any government specification or any other listed specification, a statement of that fact must appear on the purchase order. Government regulations and other listed specifications require specific lot testing, and prohibit the certification of compliance after shipment has been made. There may be additional charges associated with specification compliance testing. Please refer to IIG-CSP-3 for Certification Procedures and Charges. Call customer service for more information.

### QUALITY STATEMENT

IIG Products are designed, manufactured and tested to strict quality standards in our own facilities. This along with third party auditing is your assurance that this product delivers consistent high quality.



Industrial Insulation Group, LLC is a Calsilite/Johns Manville joint venture. IIG manufactures MinWool mineral fiber pipe, block and a variety of other insulations; Thermo-12® Gold Calcium Silicate pipe and block insulation; Super Firetemp® fireproofing board; SprouleWR-1200® Perlite pipe and block insulation; high temperature adhesives, and insulating finishing cement.

The physical and chemical properties presented herein represent typical, average values obtained in accordance with accepted test methods and are subject to normal manufacturing variations. They are supplied as a technical service and are subject to change without notice. Numerical flame spread and smoke developed ratings are not intended to reflect hazards presented by these or any other materials under actual fire conditions. Check with the Customer Service Office to assure current information. All Industrial Insulation Group products are sold subject to the IIG Limited Warranty and Limitation of Remedy. For a copy of the IIG Limited Warranty and Limitation of Remedy, email - info@iig-llc.com.



**Industrial Insulation Group, LLC**

A Calsilite/Johns Manville Joint Venture

2100 LINE STREET • BRUNSWICK, GA 31520

The **GREENGUARD INDOOR AIR QUALITY CERTIFIED®** Mark is a registered certification mark used under license through the GREENGUARD Environmental Institute.

**CUSTOMER SERVICE,  
TECHNICAL & GENERAL INFORMATION**

(800) 866-3234

[www.iig-llc.com](http://www.iig-llc.com)